



Studies of anti-angiogenic protein variants and screening of candidate tumor angiogenesis markers using Biacore systems

Intellectual Property Notice: The Biopharma business of GE Healthcare was acquired by Danaher on 31 March 2020 and now operates under the Cytiva™ brand. Certain collateral materials (such as application notes, scientific posters, and white papers) were created prior to the Danaher acquisition and contain various GE owned trademarks and font designs. In order to maintain the familiarity of those materials for long-serving customers and to preserve the integrity of those scientific documents, those GE owned trademarks and font designs remain in place, it being specifically acknowledged by Danaher and the Cytiva business that GE owns such GE trademarks and font designs.

cytiva.com

GE and the GE Monogram are trademarks of General Electric Company.
Other trademarks listed as being owned by General Electric Company contained in materials that pre-date the Danaher acquisition and relate to products within Cytiva's portfolio are now trademarks of Global Life Sciences Solutions USA LLC or an affiliate doing business as Cytiva.
Cytiva and the Drop logo are trademarks of Global Life Sciences IP Holdco LLC or an affiliate.
All other third-party trademarks are the property of their respective owners.
© 2020 Cytiva
All goods and services are sold subject to the terms and conditions of sale of the supplying company operating within the Cytiva business. A copy of those terms and conditions is available on request. Contact your local Cytiva representative for the most current information.
For local office contact information, visit [cytiva.com/contact](https://www.cytiva.com/contact)

Studies of anti-angiogenic protein variants and screening of candidate tumor angiogenesis markers using Biacore systems

In order to grow, solid tumors depend on the generation of new blood vessels to supply rapidly proliferating tumor cells with nutrients in a process termed angiogenesis. Angiogenesis requires an intricate network of signals between tumor cells, vascular endothelial cells (ECs) and the surrounding interstitium. Vascular endothelial growth factor (VEGF) and its receptors are important players in this network. The following examples from the literature show how label-free interaction analysis using Biacore™ systems has helped investigators develop therapeutic strategies by providing binding data on anti-angiogenic antibodies or soluble variants of membrane-bound receptors.

Characterization and epitope mapping of MAbs to VEGF-D

VEGF-D is believed to stimulate EC proliferation in blood vessels and is expressed in many human tumors. Its effects are mediated via the membrane-bound receptors VEGFR-2 and VEGFR-3. In order to develop tools to investigate the role of VEGF-D in tumor progression, Achen *et al.* raised four MAbs (VD1–4) against recombinant human VEGF-D (1). The antibodies were characterized using a Biacore system.

VEGF-D bound with high affinity to all four MAbs immobilized on a sensor surface, although there were marked differences in their association and dissociation rates. Detailed epitope mapping was performed by capturing VEGF-D on each of the four MAbs individually immobilized on the sensor surface and injecting the other three MAbs over the formed complex. VD1, VD2, and VD3 bound to similar or identical epitopes, whereas the more cross-reactive VD4 bound to a distinct epitope on VEGF-D (Table 1 and Fig 1).

Although cell-based bioassays showed that VD1–3 efficiently blocked activation of cell surface VEGFR-2 and VEGFR-3 by VEGF-D, it was not possible to determine whether this was due to blocking of VEGF-D binding to the receptors or

inhibition of receptor cross-linking. Biacore based inhibition assays were used to demonstrate a direct inhibitory effect of the MAbs on VEGF-D binding to both receptors. This approach also revealed that VD1 was by far the most potent inhibitor of VEGF-D binding and that VEGFR-2 and VEGFR-3 appear to bind to a similar or identical region of VEGF-D.

Table 1. Epitope mapping of anti-(VEGF-D) MAbs using Biacore system

Immobilized antibody	Injected antibody ¹			
	VD1	VD2	VD3	VD4
VD1	+	-	-	++++
VD2	+	-	-	++++
VD3	+	+	+	++
VD4	++++	+++++	++++	+++

¹ MAbs were injected over a sensor chip containing a VEGF-MAb complex. High and low binders are indicated by + and no binding is indicated by -.

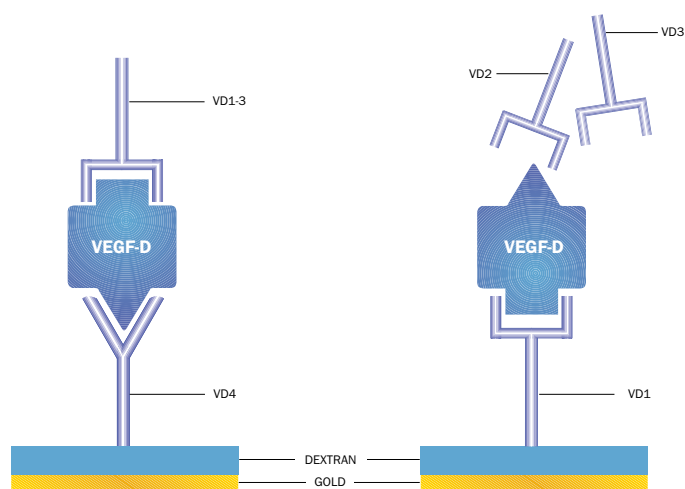

Fig 1. Biacore technology was used to demonstrate that VD1-3 bound to similar or identical epitopes on VEGF-D, whereas VD-4 was associated with a distinct epitope on VEGF-D.



Kinetic evaluation of recombinant VEGF antagonists

VEGF-165 (the major variant of VEGF-A) is a key molecule in tumor angiogenesis as it influences the behavior of ECs by activating VEGFR-1 and VEGFR-2. Recombinant, soluble variants of these receptors lacking transmembrane domains can be used to sequester VEGF-165 and block binding to the membrane-bound receptors (Fig 2), potentially inhibiting angiogenesis and preventing tumor growth.

Huang *et al.* used a Biacore assay to obtain affinity and rate constants of the interaction between a recombinant soluble version of VEGFR-2 and VEGF-165 (2). The recombinant receptor was immobilized on a sensor surface and was shown to have a similar interaction profile with both human and murine VEGF-165 (Fig 3).

Studies in cell-based assays show that heparin may be necessary for efficient VEGF-165 binding to its membrane-bound receptor, whereas a number of cell-free approaches indicate that heparin is not required for isolated receptors. Kinetic analysis on a Biacore system showed that for the soluble receptor, heparin actually inhibited the interaction and that this was due to a reduction in the association rate of VEGF-165 binding to VEGFR-2. Label-free interaction analysis enabled the investigators to establish the baseline parameters for binding of soluble VEGFR-2 to VEGF-165 and to eliminate the potential problem of a heparin requirement for this interaction in therapeutic applications. The authors also stated that this Biacore-based method may be valuable in assessing engineered therapeutic variants of VEGFR-2.

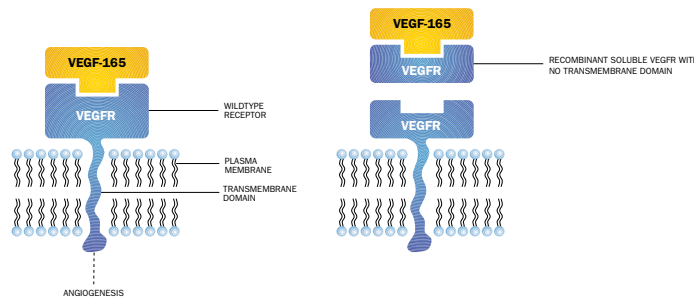

Fig 2. VEGF activates the receptors VEGFR-1 and VEGFR-2. Recombinant variants of these receptors that lack transmembrane domains can sequester VEGF, blocking its binding to the membrane bound receptors and inhibiting angiogenesis.

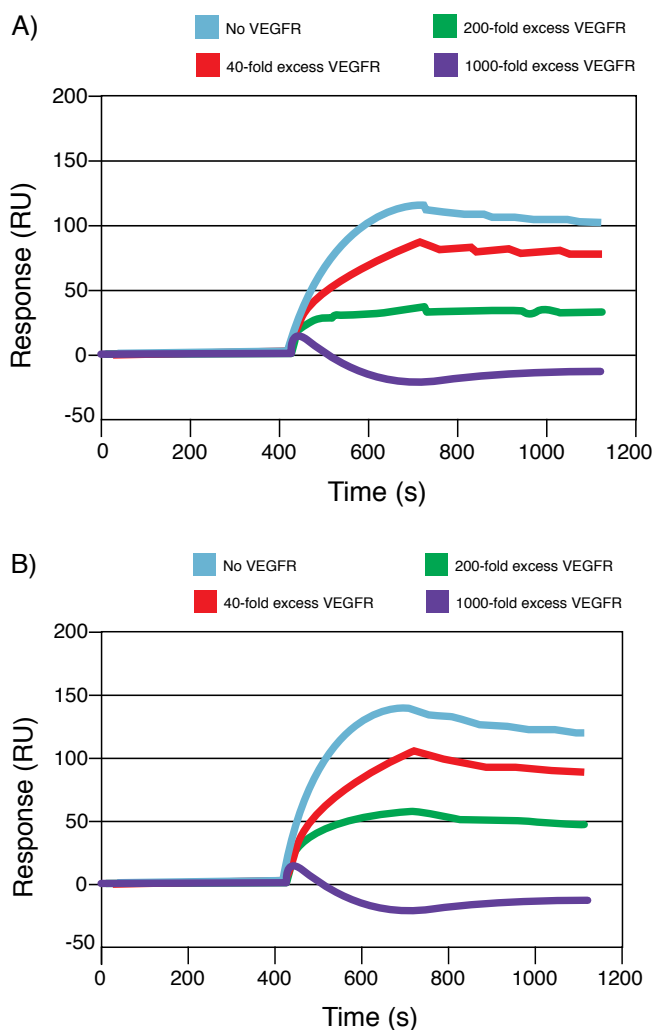

Fig 3. Inhibition of VEGF binding to immobilized VEGFR by excess of soluble recombinant VEGFR. Concentrations of soluble recombinant VEGFR in solution are 0, 40-fold, 200-fold, and 1000-fold molar excess over VEGF. Concentration of VEGF is 5 nM. A) human VEGF-165; B) mouse VEGF-165.

Optimizing antibody fragments as tumor-specific biomarkers

MAbs to tumor-specific antigens are potentially useful for diagnostic imaging and targeted human cancer therapy. Human antibody fragments from phage libraries may be even more attractive for such applications since they would be expected to show improved bioavailability compared to whole antibodies.

B-FN is a variant of fibronectin, a ubiquitous extracellular matrix protein, containing a novel splice-generated domain (ED-B). This isoform is found in the stroma of fetal and neoplastic tissues and in the walls of developing neoplastic blood vessels, but is absent from normal adult tissues. An antibody fragment directed against the ED-B domain should, therefore, be specific to tumors. Neri *et al.* designed a generic tumor-specific antibody fragment against ED-B (3). In addition to a single chain anti-ED-B antibody fragment, they also generated a number of single chain and dimeric variants for testing in clinical trials.

Biacore assays were used to screen antibody fragment libraries and compare interaction profiles with immobilized ED-B (Fig 4). Affinities of the antibody fragments varied 100-fold (K_D values between 1.1×10^{-9} to 1.1×10^{-7} M), with increases in affinity compared to the initial fragment deriving mainly from slower dissociation rates. The authors then tested the performance of these fragments in targeting tumors *in vivo* using real-time photodetection of fluorescently labeled antibodies and showed that the most efficient targeting fragments were those that dissociated slowly from ED-B in Biacore assays. Label-free interaction analysis on Biacore systems proved invaluable in selecting optimal antibody fragments for diagnostic imaging, which may form the basis of future therapeutic strategies targeted at tumor vasculature.



Fig 4. Biacore system was used to screen Ab fragment libraries to compare binding properties to ED-B immobilized on a Biacore sensor chip.

Monitoring protein interactions with Biacore systems

Biacore systems monitor protein interactions in real-time using a label-free detection method. One of the interacting molecules is immobilized onto a sensor surface, while the other is injected in solution and flows over the sensor surface. As molecules from the injected sample bind to the immobilized molecules, this results in an alteration in refractive index at the sensor surface that is proportional to the change in mass concentration. Using the phenomenon of surface plasmon resonance (SPR), these changes are detected in real-time and data are presented as a sensorgram (SPR response plotted against time). Sensorgrams display the formation and dissociation of complexes over the entire course of an interaction, with the kinetics (association and dissociation rates) revealed by the shape of the binding curve.

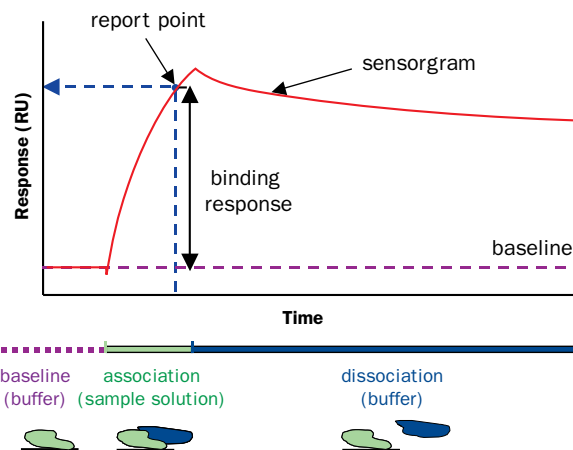

The sensorgram provides real-time information about the entire interaction, with binding responses measured in resonance units (RU). Binding responses at specific times during the interaction can also be selected as report points. More information can be found at www.gelifesciences.com/biacore

References

1. Achen, M. G., *et al.* Monoclonal antibodies to vascular endothelial growth factor-D block its interactions with both VEGF receptor-2 and VEGF receptor-3. *Eur. J. Biochem.* **267**, 2505–2515 (2000).
2. Huang, X., *et al.* Expression of soluble VEGF receptor 2 and characterization of its binding by surface plasmon resonance. *Biochem. Biophys. Res. Commun.* **252**, 643–648 (1998).
3. Neri, D., *et al.* Targeting by affinity-matured recombinant antibody fragments of an angiogenesis associated fibronectin isoform. *Nat. Biotechnol.* **15**, 1271–1275 (1997).

For local office contact information, visit www.gelifesciences.com/contact

GE Healthcare Bio-Sciences AB
Björkgatan 30
751 84 Uppsala
Sweden

www.gelifesciences.com/biacore

GE, imagination at work, and GE monogram are trademarks of General Electric Company. Biacore is a trademark of GE Healthcare companies.

All third party trademarks are the property of their respective owners.

© 2006-2008 General Electric Company—All rights reserved. First published June 2006.

All goods and services are sold subject to the terms and conditions of sale of the company within GE Healthcare which supplies them. A copy of these terms and conditions is available on request. Contact your local GE Healthcare representative for the most current information.

GE Healthcare UK Ltd., Amersham Place, Little Chalfont, Buckinghamshire, HP7 9NA, UK.

GE Healthcare Europe, GmbH, Munzinger Strasse 5, D-79111 Freiburg, Germany.

GE Healthcare Bio-Sciences Corp., 800 Centennial Avenue, P.O. Box 1327, Piscataway, NJ 08855-1327, USA.

GE Healthcare Bio-Sciences KK, Sanken Bldg., 3-25-1, Hyakunincho, Shinjuku-ku, Tokyo 169-0073, Japan.



imagination at work