

SIA Kit Au

Instructions for Use

Product description

Order code: BR-1004-05

Contents:

- Sensor Surface Au (pack of 10) (A)
- Sensor Chip Assembly Unit classic (B)
- Sensor Chip Assembly Unit Series S (C)
- Protective Sheath classic (D)
- Sensor Chip Support classic (pack of 10) (E)
- Sensor Chip Support Series S (pack of 10) (F)
- Protective Sheath Series S (G)
- Double-sided Adhesive (pack of 16) (H)

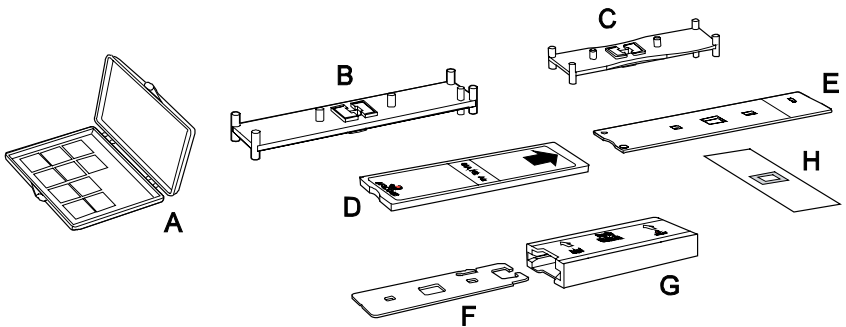

Storage: +2°C to 8°C

For use with: All Biacore™ systems, except Biacore 4000, Biacore A100, and Biacore S51.

Note: For *in vitro* use only.

Intended use

SIA Kit Au is designed for interaction analysis in Biacore systems. Plain gold surfaces are delivered with separate Sensor Chip Supports to allow preparation of user-defined surface chemistries using procedures that the plastic may not tolerate.

Preparation for use

Step	Action
1	If working in a humid environment, allow the Sensor Surface Au packet to equilibrate at room temperature for 30 minutes in order to: <ul style="list-style-type: none">• allow the sensor surfaces to be released from the gel• prevent condensation on the sensor surfaces
2	Open the packet in a designated area in which measures have been taken to minimize dust levels. A laminar air flow bench or similar environment is ideal for all work with sensor surfaces. The surface is located in the gel pack with the gold side up.

Step	Action
------	--------

- | | |
|---|--|
| 3 | <p>Pick a sensor surface from the gel with a pair of clean tweezers.</p> <p>Hold the sensor surface with the tweezers by the edges only. The sensor surface can be held securely with one arm of the tweezers on the glass side and the other on the gold side, provided that the tweezers do not make contact with the gold coating inside a 2 mm wide area at the edges of the sensor surface. The 2 mm wide area where the sensor surface can be held with a pair of tweezers is shown in the illustration below.</p> |
|---|--|

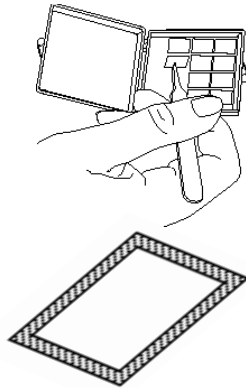

Note:

Keep track of which side carries the gold coating.

- | | |
|---|---|
| 4 | <p>If required, clean the gold surface with appropriate solutions (ethanol or piranha solution) prior to coating.</p> |
|---|---|

Assembling the sensor chip

The illustrations in the following instructions show assembly of a sensor chip on a Sensor Chip Support of the classic format only. Corresponding steps are taken also for the Series S format.

Step Action

- 1 Place the Sensor Chip Support of appropriate format on the corresponding Sensor Chip Assembly unit. The Sensor Chip Support can be oriented in one way only.

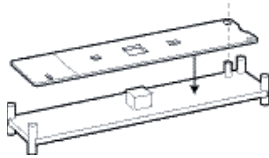

- 2 Take an adhesive strip, remove the white protective cover and place the adhesive backing with adhesive on the Sensor Chip Support. Press the adhesive against the support and remove the adhesive backing. Remove the support with adhesive from the assembly unit and turn the unit around.

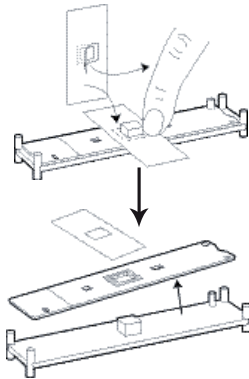

- 3 Place the user-modified sensor surface into the well on the assembly unit with the glass side facing the unit. Make sure that the sensor surface lies steadily.

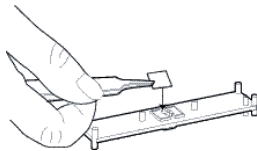

Step Action

- 4 Place the support with adhesive on the unit and press firmly to fasten the sensor surface to the support. The Sensor Chip Support can be oriented in one way only.

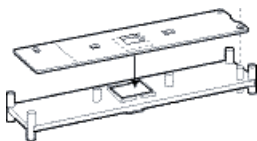

- 5 Ensure that the glass side of the sensor surface is clean. A lint-free cloth can be used to wipe the glass side and/or pressurized nitrogen, or air can be used to blow away particles. The pressurized gas must be of high quality. In particular, it must be free from vaporized oil particles, which occur abundantly in air from many compressors.
- 6 Insert the Sensor Chip Support with mounted sensor surface fully into the Protective Sheath. Ensure that the sensor surface is correctly orientated, see the following tables for further instructions.

Follow the instructions below to orientate the classic format.

Item	Orientation	Illustration
Protective Sheath	Labelled side facing upwards.	
Support with sensor surface	Adhesive side (glass side) facing upwards.	
The rectangular hole in the Sensor Chip Support	Disappearing last into the Protective sheath of the five holes in the Sensor Chip Support.	

Follow the instructions below to orientate the Series S format.

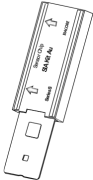
Item	Orientation	Illustration
Protective Sheath	Labelled side facing upwards.	
Support with sensor surface	Adhesive side (glass side) facing upwards.	
The “jaws” of Sensor Chip Support	This end of the Sensor Surface Support goes first into the Protective Sheath.	

Docking the sensor chip

Step	Action
1	Prepare the Biacore instrument with new running buffer. The buffer should be filtered (0.22 mm) and degassed.
2	Insert the sensor chip in the Biacore instrument and dock, as described in the instrument handbook.
3	When the sensor chip is undocked and taken out from the instrument, always slide out the Sensor Chip Support and check that the sensor surface is still attached to the frame.
4	Sensor chips that are not docked in the instrument should be stored in closed containers.

Interaction analysis

Interaction analysis is performed as analytes in solution are injected over the user-modified Sensor Surface Au.

Refer to Biacore Handbooks and cytiva.com/biacore for details on experimental protocols and methodology.

Page intentionally left blank



[cytiva.com/sampleprep](https://www.cytiva.com/sampleprep)

Cytiva and the Drop logo are trademarks of Global Life Sciences IP Holdco LLC or an affiliate.

Biacore is a trademark of Global Life Sciences Solutions USA LLC or an affiliate doing business as Cytiva.

All other third-party trademarks are the property of their respective owners.

© 2020 Cytiva

All goods and services are sold subject to the terms and conditions of sale of the supplying company operating within the Cytiva business. A copy of those terms and conditions is available on request. Contact your local Cytiva representative for the most current information.

For local office contact information, visit [cytiva.com/contact](https://www.cytiva.com/contact)

22057521 AG V:6 07/2020