

# HyClone™ buffers and process liquids

Workflow solutions



# Our customer focus

Cytiva continues the mission of being the leading supplier of quality solutions to challenges faced in life science research and the biopharmaceutical industry. A consistent global quality management system ensures security of supply of buffers and process liquids, with equivalent quality standards and performance across the globe. With a strong commitment to progress and growth, our customers' needs fuel our development of innovative products and solutions for both upstream and downstream workflows.

## We offer

- Product excellence, customer-centricity, and innovation for more than 45 years
- Global production facilities, providing on-time delivery
- Custom bulk production services for bioproduction scale-up
- Supply chain partnership for efficient and cost-effective solutions
- Products and solutions for both upstream and downstream applications



# Our buffers and process liquids feed the entire bioproduction workflow

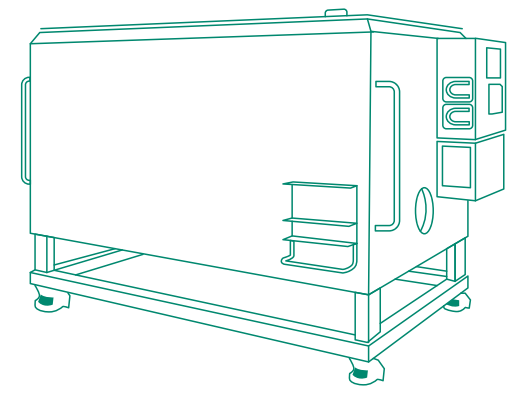

Xcellerex™ XDUO mixer system

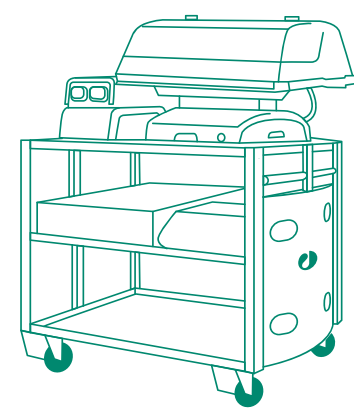

WAVE Bioreactor™ system and ReadyKart

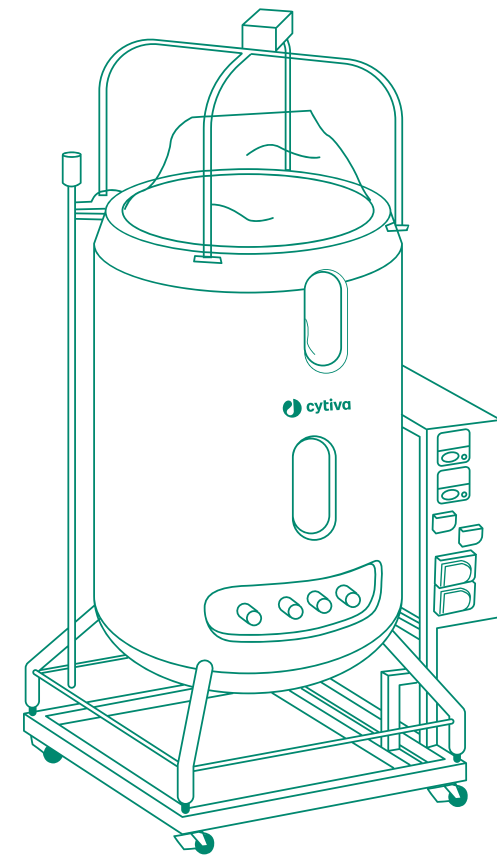

Xcellerex XDR bioreactor system

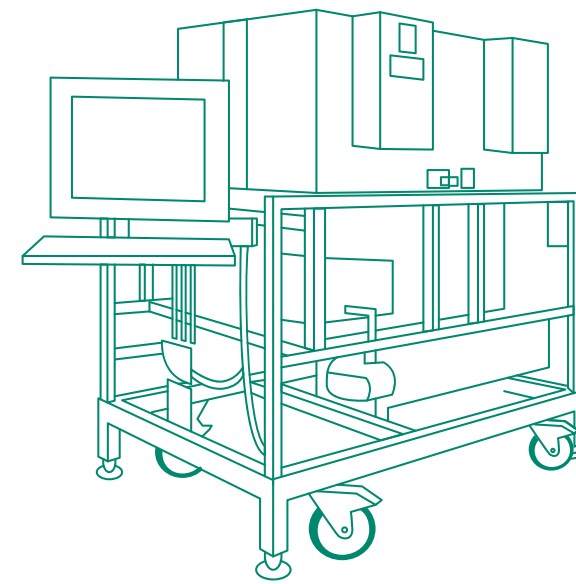

Inline Conditioning system

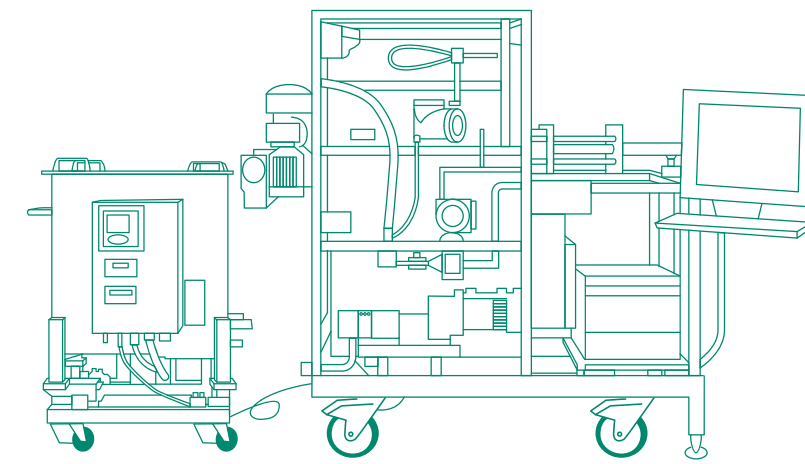

UniFlux™ crossflow filtration system with Xcellerex Quad mixing system

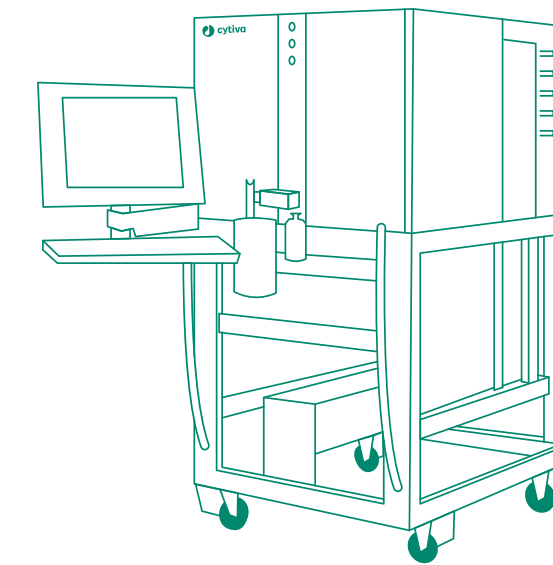

ÄKTAprocess™ chromatography system

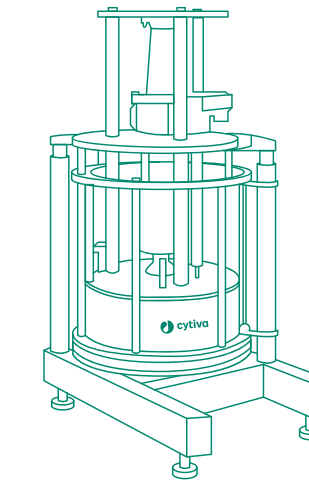

AxiChrom™ column

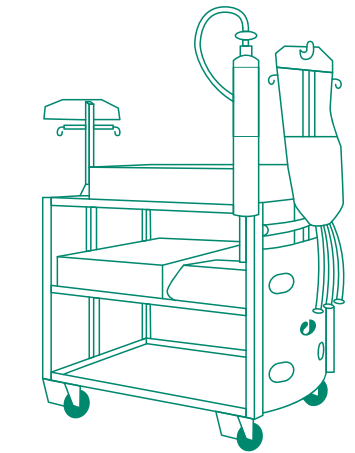

ReadyToProcess™ hollow fiber filtration cartridge

## Media hydration and supplementation

Water for injection (WFI) quality water and glucose solutions

## Cell handling and harvest

Buffers and balanced salt solutions

## Filtration

Flush and digestion solutions

## Buffer preparation, in-line conditioning and dilution

Buffered saline solutions, WFI quality water, buffer concentrates, and stock solutions

## Viral inactivation

Acids, detergents, and surfactants

## Chromatographic operations

Custom buffers; phosphates, citrates, acetates, Tris, HEPES, and more

## Column regeneration, cleaning, and storage

Ethanol, NaOH, and NaCl solutions

## Washing and rinsing

Water and dilute salt solutions

## System cleaning and sanitization

Water, ethanol and NaOH solutions

# Breaking the bottleneck

## Focusing critical resources

Buffer production suites and the required utilities to run them are major capital investments when building a bioproduction facility. Additionally, buffer manufacturing is one of the more resource-intensive activities and can rapidly become a bottleneck in the overall workflow. Because of this, many facilities are quickly outgrowing capacity and ultimately become undersized.

We can help free up space by providing just-in-time, high-quality custom and standard bulk fluids in containers and packaging sizes of your choice for both upstream and downstream applications.

## Customization

Development and scale-up of bioprocesses frequently require quick manufacture of prototype buffers to facilitate timely process evaluation and fast implementation. Cytiva offers Rapid Response Production (RRP) services for fast delivery of small volumes of prototype buffers, which can easily be transferred to GMP production.

## GMP custom products

As an expert in custom buffer supply, we set up, manufacture, and deliver hundreds of new customer-specific formulations yearly. Because successful bioproduction requires many, often unique, solutions, we tailor each solution to your specific formulation and packaging requirements.



# Global manufacturing

Our manufacturing facilities are designed to meet stringent regulatory production and distribution requirements, while serving the global biopharmaceutical market. With facilities around the world, we are able to provide buffers and process liquids in lot sizes and delivery systems suitable for your application.

Buffers and process liquids are produced in traditional stainless steel tanks or in single-contact manufacturing systems. We also offer dedicated animal-derived component free (ADCF) mixing systems where appropriate. We can provide liquid products in our HyClone single-use bags and bottles.

For preblended powdered buffers, our pin mill powder manufacturing facility offers a high level of quality and consistency. Additionally, we offer technical support for hydration at your facility.

## Traditional stainless steel tanks

- Up to 10 000 L batch capacity
- Closed system sterile filling

## Single-use manufacturing systems

- Up to 10 000 L batch capacity
- ADCF film contact surface

## Powder manufacturing

- > 6000 kg powder manufacturing batch capacity
- Dedicated ADCF powder facility



# Flexible packaging

By combining our large-scale production capabilities with efficient packaging options, buffers and process liquids can be delivered to your facility when you need them, allowing you to focus resources on your core capabilities: manufacturing of biotherapeutics and vaccines.

We have a wealth of experience in providing buffers and process liquids in large-volume delivery systems. These systems have been extensively tested for product integrity and comply with internationally recognized transportation requirements. We work with clients to customize delivery systems that support ease-of-use in your facility.

Buffers and process liquids are packaged in HyClone single-use bags and bottles and shipped in the following configurations:

- Corrugated shippers for single-use container volumes in the 500 mL to 20 L range
- Bottom-drain drums for single-use container volumes in the 50 to 200 L range
- UN liquid-rated drums for single-use container volumes in the 20 to 200 L range
- Palletized bins for single-use container volumes in the 250 to 1000 L range

## Logistics

Our logistics experts arrange and ship multiple domestic and international shipments every month in air, land, and ocean containers. Logistics experts coordinate customer shipments and work with regulatory agencies to ensure domestic and international trade compliance.

Shipments can be managed frozen (-20°C), cold (2°C to 8°C), or in ambient temperature; in insulated small packages or pallets in active-temperature freight containers and temperature-controlled trucks. Temperatures are monitored using data recorders to ensure consistency and reliability.



# Commitment to quality

Throughout the design and manufacturing process, every aspect of your HyClone product meets stringent quality requirements and offers a high level of performance. We take a three-step approach to quality control for HyClone products: quality by design, process control, and key attribute performance testing.

Quality by design at Cytiva means evaluating suppliers; performing design failure mode effect analysis and process failure mode effect analysis; conducting design of experiments; and building quality into the manufacturing facility design.

Process control enables consistent processes that continue to improve. We rely on statistical process control; process qualification and validation; and continuous improvements. Key attribute performance testing allows us to test products for quality at every stage of the manufacturing process, even well before the process starts with raw material testing, in-process testing, and finished goods testing.

With rigorous quality management systems, we consistently meet internationally recognized regulatory requirements and customer expectations throughout our collaborative process.

## Quality management

To meet your documentation and regulatory requirements, our quality management is consistent in procedure and raw materials for lot-to-lot equivalence across our global manufacturing sites. Our segregated ADCF manufacturing uses single-use liquid management systems that minimize cleaning and cleaning validation requirements and alleviate cross-contamination concerns.

## Validated, documented, and aligned production according to:

- Medical device current good manufacturing practices (GMP) 21 CFR 820
- ISO 13485 for medical devices
- ISO 9001
- Eudralex Annex 1 aligned

## Raw materials

- Robust vendor management program to enable sourcing from qualified and audited raw material suppliers
- Multiple qualified raw material sources for risk mitigation and contingency planning purposes
- Raw materials meeting our quality requirements as well as requirements of United States, European, and/or Japanese pharmacopeia

## [cytiva.com/hyclone](https://www.cytiva.com/hyclone)

Cytiva and the Drop logo are trademarks of Life Sciences IP Holdings Corp. or an affiliate doing business as Cytiva.

ÄKTApocess, AxiChrom, HyClone, ReadyToProcess, WAVE Bioreactor, UniFlux, and Xcellerex are trademarks of Global Life Sciences Solutions USA LLC or an affiliate doing business as Cytiva.

© 2020–2023 Cytiva

For local office contact information, visit [cytiva.com/contact](https://www.cytiva.com/contact)

CY14251-18Sep23-BR

