

# Xcellerex™ Automated Perfusion System

## CELL GROWTH AND EXPANSION

Designed to address your needs for flexibility, reliability, and simplicity in upstream perfusion applications, Xcellerex™ Automated Perfusion System (APS) is a single-use system for both process development and production. Use this tangential flow filtration (TFF)-based system (Fig 1) for intensified cGMP manufacture of preclinical and clinical material. Perform a variety of upstream applications including classic steady state and N-1 perfusion, as well as techniques using ultrafilters, by integrating this multifunctional system with Xcellerex™ XDR bioreactors.

- Simplify operations by integrating all perfusion operations into a single platform – bioreactor, cell retention, fluid management, and automation – and accessing via one user interface that generates a single batch report.
- Minimize capital expenditure with a single system that supports your volume needs from < 50 L to 500 L.
- Achieve high-density cell cultures with the system's low-shear recirculation pump that minimizes impact on cell viability.
- Maintain optimal filter performance and minimize user intervention with intelligent filter switching that avoids the need for a backup system.
- Reduce manual interactions with automated liquid management that controls media and permeate bin switching.
- Maximize flexibility by using standard ReadyToProcess™ hollow fiber cartridges in a wide range of sizes for both microfiltration and ultrafiltration applications.

## Xcellerex™ APS

Xcellerex™ APS integrates with three bioreactors in the Xcellerex™ XDR family (50, 200, and 500 L) to enable perfusion capability. The novel perfusion control strategy with accurate process control enhances reproducibility, predictability, and reliability. The system consists of a cabinet constructed with 316L grade stainless steel and reinforced with an internal 316L grade stainless steel frame. The frame is supported with four casters that are cleanroom grade, non-scuffing, NSF listed. The cabinet holds process components (recirculation pump and



**Fig 1.** Xcellerex™ APS single-use perfusion system.

perfusion media addition pump, permeate and cell bleed pump, and pinch valves) as well as the single-use flow kit. The kit is intuitive to install, enabling rapid, error-free startup.

It is possible to obtain real-time filtration performance data using the flow kit which incorporates pressure and flow sensors for monitoring key process parameters. Xcellerex™ APS allows a simpler supply chain by using a single supplier for the complete operation. Traceability and cybersecurity are supported with user friendly, 21 CFR part 11 enabled software.

## Pumps

Xcellerex™ APS uses a Levitronix™ single use maglev centrifugal pump on the recirculation feed (Fig 2). This pump was chosen for its low-shear properties and has a proven record in cell culture perfusion applications. The pump operates in the range of 1 to 18 liters per minute (LPM). The system also includes three peristaltic pumps that operate at variable speeds for media addition to the bioreactor, cell bleed to maintain steady state, and delivery of the permeate to one of the two collection bins.



**Fig 2.** Levitronix™ single-use maglev pump.

## Filter holder

Xcellerex™ APS is designed to operate with a maximum of two ReadyToProcess™ hollow fiber cartridges mounted vertically with the feed inlet at the bottom and the retentate outlet at the top. The system can accommodate multiple cartridge and pore sizes and is designed for both microfiltration (MF)- and ultrafiltration (UF)-based perfusion applications. This flexibility combined with the ability to run multiple perfusion applications allows users to optimize the process to their specific perfusion needs.

## Xcellerex™ APS Flow Kit

The single-use flow kit is supplied presterilized, gamma irradiated, bioburden free, and ready for use. It consists of four sections for: recirculation feed; permeate; retentate; and perfusion media and is designed to minimize hold-up volume and maximize product recovery (Fig 3). The flow kit includes the single-use pump head and tubing, plus precalibrated sensors for pressure and flow terminating with ReadyMate™ connectors for aseptic connection. Color schemes are displayed to ease the installation of the flow kit. A continuous test on the sensors runs in the background to ensure proper functionality.

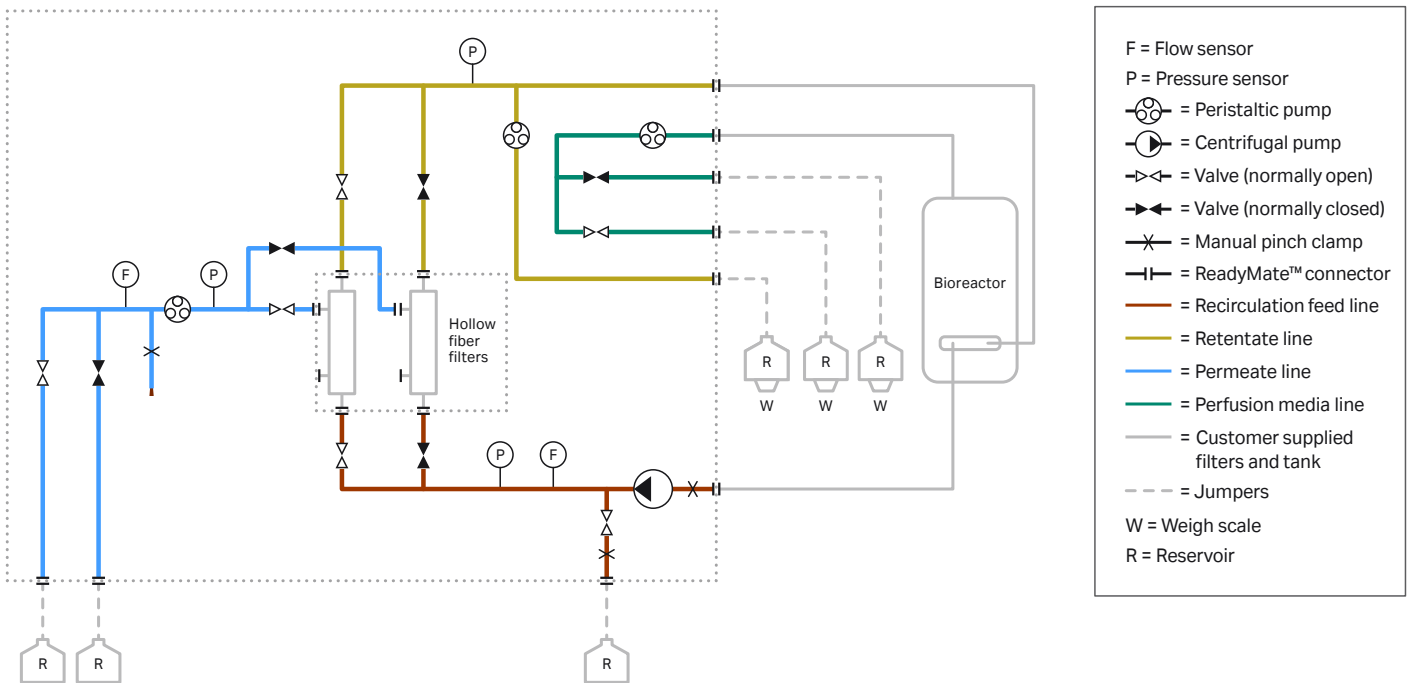

**Fig 3.** Schematic showing a single-use flow kit for Xcellerex™ APS.

## Recirculation flow path

The recirculation flow path consists of the recirculation feed line, the ReadyToProcess™ hollow fiber filter, and the retentate line. The recirculation feed line serves to transfer cell culture supernatant from the bioreactor via the recirculation pump to the hollow fiber filter. A cell harvest line allows the bioreactor to be emptied post-run using the Xcellerex™ APS without an external pump.

The flow path can house up to two hollow fiber filters (primary and secondary filter). At a given point only one filter is in use. When the filter performance decreases, the intelligent filter switch feature is activated based on user-specified parameters, and the secondary filter comes online. Filter performance is constantly monitored through online pressure sensors on the feed, retentate, and permeate sections of the flow path.

## Permeate flow path

The permeate flow path directs the product of interest (e.g., steady-state perfusion) or spent media (e.g., with N-1 applications) to a collection vessel. A novel feature with Xcellerex™ APS is the automated permeate reservoir switch that automatically switches to a new collection vessel when the first one is full. The switch-over is based on the permeate reservoir size and is set by the user.

The permeate line is designed to support up to two single-use permeate collection bags. A pressure sensor located before the permeate pump calculates the permeate pressure, and a flow meter after the pump monitors the permeate flow rate. A sampling line terminating with a luer twist-lock in the permeate line allows frequent sample collections. The tube length also facilitates the sterile welding of a sample bag.

## Perfusion media flow path

Xcellerex™ APS delivers perfusion feed media to the bioreactor. The system is designed to support up to two single-use media storage bags that are placed on weigh scales connected to the system (see *Specifications* section for details). The continuous weight monitoring allows automated switching of perfusion media when the primary bin is emptied.

## Cell bleed flow path

The desired cell density within a steady-state perfusion operation is achieved through cell bleed where a specified percentage of the bioreactor working volume is removed each day. Xcellerex™ APS automates the cell bleed through a dedicated flow path. A bin placed on a weigh scale is used to provide feedback to monitor the bleed flow rate.

Weight monitoring for cell bleed can be continuous or in a bolus bleed mode. The weight monitoring setup supports floor scales with PROFIBUS™ or Ethernet/IP communication interfaces.

## Perfusion bag

Xcellerex™ Automated Perfusion System bioreactor bags provide seamless connectivity to the Xcellerex™ bioreactor and flow kits. The bags have been designed with perfusion applications in mind and can be used in all processes covered in the Xcellerex™ APS validation guide.

## Alternating permeate flow (APF)

The alternating permeate flow (APF) allows the user to define high and low setpoints for the permeate flow. The APF encourages filter longevity by repetitive back pressure on the permeate side, which prevents lodging of cell debris in the filter pores.

## Integrated control with Wonderware™ software

The Xcellerex™ APS control system uses Wonderware™ software running on a Microsoft® Windows® server operating system. The user interacts with the instrument using the X-Station (touchscreen, keyboard, and mouse). The perfusion overview screen can be accessed from the perfusion tab. The control system provides the status of all the instrument modules as well as alarm and event notifications. The graphical user interface (GUI) visually represents the process flow where all parameters can be accessed through Wonderware™ screens for monitoring, controlling, viewing, and modification (Fig 4). An integration into other automation infrastructures could be realized via the Ethernet IP interface.

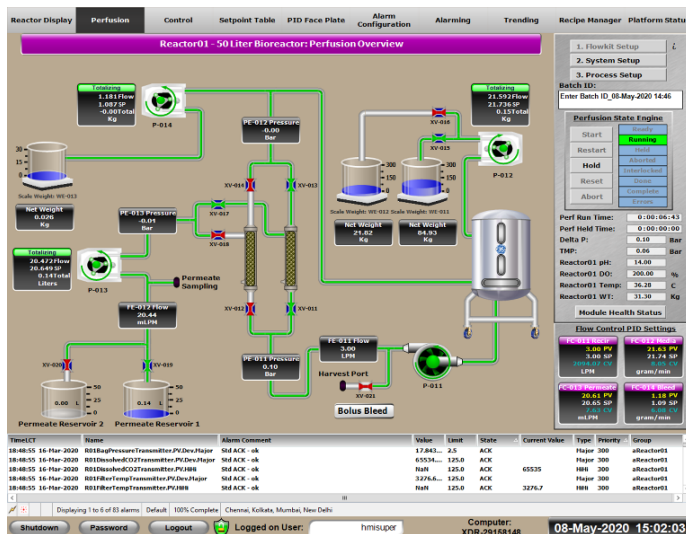

Fig 4. Xcellerex™ APS graphical user interface.

# Enabling technologies for Xcellerex™ APS

## Bins and floor scales

A wide range of single-use 3D vessels, such as ReadyToProcess™ bins, can be fitted to Xcellerex™ APS. The basic requirement is that the floor scales are suitably sized for the volumes of cell culture media to be used. The number of floor scales and bins will vary depending on the required volume of cell culture. This feature enables the weight monitoring to perform automated bin switching of the perfusion media flow when the active bin is depleted.

## Xcellerex™ bioreactor

The Xcellerex™ XDR bioreactor product line offers the benefits of single-use technology and stirred-tank design in a modular turnkey platform. XDR units are designed to deliver scalable performance in batch, fed-batch, and perfusion good manufacturing practices (GMP) operations. Xcellerex™ APS has been designed for seamless integration with the 50 L, 200 L, and 500 L XDR bioreactors (see *Prerequisites* section for details). Figure 5 shows the setup with an XDR-500 bioreactor.

## Hollow fiber filters

ReadyToProcess™ hollow fiber cartridges come preconditioned, presterilized, and with ReadyMate™ disposable connectors attached to allow rapid installation and startup when used with Xcellerex™ APS. Up to two filters can be installed on the system at one time, and it accommodates multiple pore sizes (UF and MF), path lengths (30 and 60 cm), and membrane areas (0.12 to 4.4 m<sup>2</sup>). This allows use of Xcellerex™ APS in many different perfusion applications. Typical applications are shown in Figure 6.

## Material compliance

All wetted polymer materials and/or pressure holding parts have been tested and classified according to USP <88> Class VI; USP 87 (Cytotoxicity), AOF/EMA/410/01. Used materials are traceable



Fig 5. Xcellerex™ APS with Xcellerex™ XDR-500 bioreactor.

back to their production batches. The flow path is produced and packed under controlled conditions in a cleanroom environment (ISO 14644-1 class) using validated procedures. Each Xcellerex™ APS flow kit is packed in double plastic bags to protect against contamination and is gamma irradiated (25 to 40 kGy). The flow kit with ReadyMate™ connectors has a sterile fluid path, with its sterility assurance level verified quarterly through sterility and bioburden testing.

The system hardware is CE marked, and an EU Declaration of Conformity is part of the documentation. The system hardware is also compliant with UL508A.

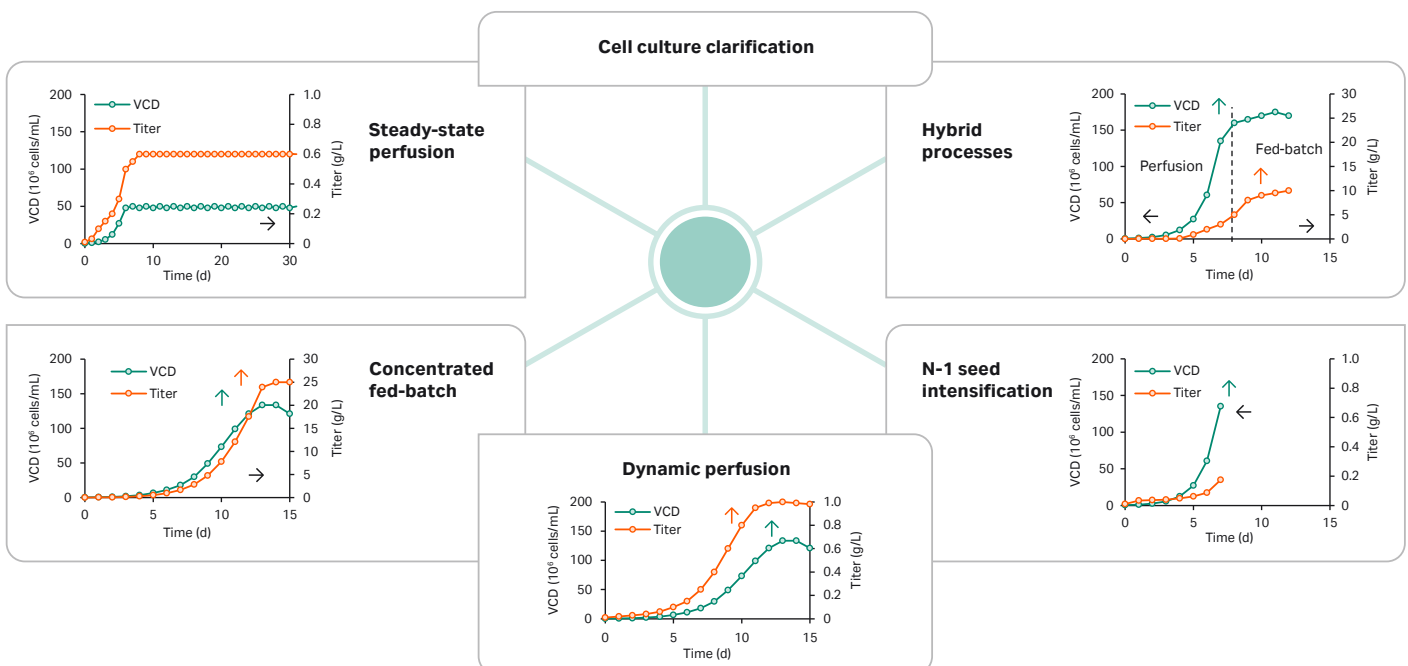
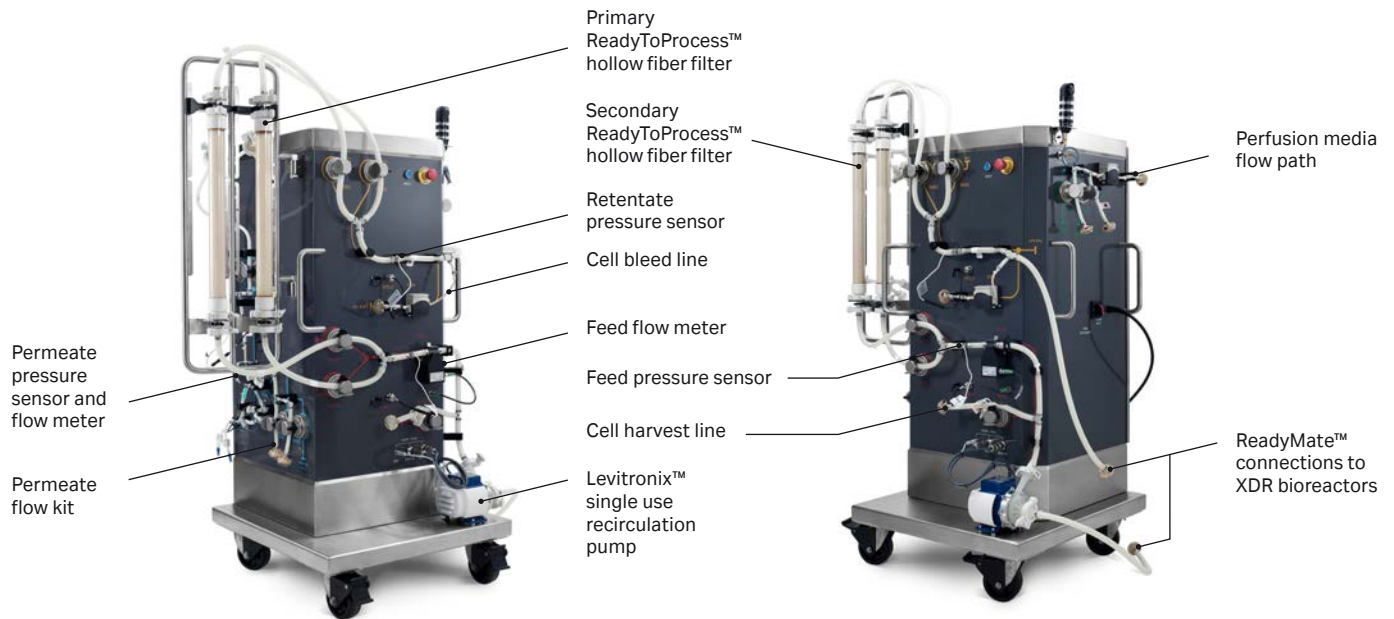

Fig 6. Typical perfusion applications for Xcellerex™ APS.



**Fig 7.** Xcellerex™ APS components.

## Product documentation and services

Regulatory authorities expect manufacturers of pharmaceuticals to qualify equipment before use in production. Process safety is an integral part of the Xcellerex™ APS design, including the single-use flow kit and control software. The system is supported with an extensive documentation package.

Multiple documents are available to support biologics manufacturers with information about the flow kit, the system hardware, and control software. Detailed operating instructions (OI), site preparation guide (SPG), unpacking instructions (UPI), hardware product documentation (HWPD), flow kit product documentation, automation user manual, and flow kit validation guide are available for reference.

Product documentation delivered with the system and flow kit are:

- Validation guide: includes a description of the flow kit manufacturing process, qualification tests, and extractable information. It is available on request via the web site.
- Release documentation: delivered with a functional test protocol. The flow kit is also delivered with a certificate of quality, including product release criteria.
- The system can be delivered with installation and operational qualification (IQ/OQ) documentation, and the qualification can be performed by certified Cytiva specialists.

System components are shown in Figure 7.

## Specifications

### General specifications

Instrument footprint Dimensions (W × D × H)	800 × 900 × 1720 mm
Weight, main system	200 kg
Software	Wonderware™
Power outlet	100–120 V~ 220–240 V~
AC voltage frequency	50/60Hz
Max. power consumption	≤1 kVA
Ingress protection	IP45
Compressed air interface	5.5–7 bar, 50 NL/min, oil- and particle-free
Weight scale communication	PROFIBUS™ and Ethernet/IP interface
Auxiliary inputs	4–20 mA

### Recommended operating conditions

Ambient temperature	16°C to 30°C
Process Liquid temperature	28°C to 37.5°C
Liquid pressure	-0.4 to 1 bar
Fluid density (max)	1200 kg/m <sup>3</sup>
Max supported fluid viscosity at 37°C	
Recirculation	4 cP
Permeate	1 cP

### Hollow fiber filter specifications for Xcellerex™ APS\*

Max. no. of cartridges	2
Cartridge size	5, 6, 8, 9, 35, 45, 55, and 65
Filter area	0.12–4.4 m <sup>2</sup>

\* For a list of available cartridges see tables at end of document.

## Flow rates

Recirculation feed pump flow	50 L: 1 to 9.2 LPM 200 L: 1.5 to 18 LPM 500 L: 3.7 to 18 LPM
Perfusion media pump flow	50 L: 1.1 to 208 mL/min 200 L: 2.2 to 555 mL/min 500 L: 4.9 to 625 mL/min
Permeate pump flow	50 L: 1.1 to 208 mL/min 200 L: 2.2 to 555 mL/min 500 L: 4.9 to 625 mL/min
Bleed pump flow	50 L: 0.75 to 8.7 mL/min 200 L: 1.5 to 34.7 mL/min 500 L: 3.3 to 86.8 mL/min

## Flow Kit specifications

Kit tubing diameter (ID)	6.35 and 12.7 mm
Connectors, type/size	ReadyMate™ connectors
Peristaltic pump tube diameter (ID)	3.2 and 4.8 mm
No. of fluid inlets/outlets	2/4
Shelf life	18 months
Max. operating pressure	1 bar

## Sensor specifications

Flow sensor	Range	Accuracy
Recirculation feed	1 to 18 L/min	10% of reading or $\pm 0.25$ L/min, whichever is greater
Permeate	66 to 37 500 mL/h	$\pm 10\%$ of reading or $\pm 0.066$ L/h
Pressure sensor (recirculation feed, retentate, and permeate)	0.1 to 1 bar g	$\pm 0.15$ bar for recirculation flow rate 1 to 12 L/min $\pm 0.25$ bar for recirculation flow rate > 12 L/min

## Prerequisites to an integrated setup of Xcellerex™ APS and XDR\*

Supported bioreactors	Standalone XDR-50, XDR-200, XDR-500 with Dual Panel (cell culture/dual purpose)
Supported software	Wonderware™ 2014 or newer
Supported X-Station configuration	Dell Server R430/R440; Compact Logix PLC 1769-L33ER; configured for 2 Vessel support only
Max. supported impeller rpm	XDR-50: 110 rpm XDR-200: 150 rpm XDR-500: 150 rpm
Max. supported sparge rates through sparge discs	0.1 VVM through 1 mm holes; 0.05 VVM through 20 micron
Supported bioreactor impeller direction	Upward pumping
Supported weigh scale terminal	Mettler-Toledo IND570; Sartorius Combiics™ 2
Supported weigh scale interface	Ethernet/IP or PROFIBUS™

\*Contact your local representative for upgrade options.

## Ordering information

Product	Description	Product code
Xcellerex™ APS	Main instrument	29297750
Flow Kit-L-ET*	Flow kit	29377110
Flow Kit-L	Flow kit	29377111
Jumper 0.375IN x 16.5 FT	Jumper	29496408
50 L APS bioreactor bag	Bioreactor bag	29605397
200 L APS bioreactor bag	Bioreactor bag	29605400
500 L APS bioreactor bag	Bioreactor bag	29605403

\*The flow kit L-ET configuration can be used for applications running for greater than 30 days, however, the flow kit should be tested to the process conditions set by the Customer.

Fittings and accessories	Description	Product code
Xcellerex™ APS Tube Support	Accessory	29461525
Xcellerex™ APS Filter Stopper	Accessory	29461526
Xcellerex™ APS Tubing Clip	Accessory	29516102
Tube Assy. ReadyMate™ to ReadyMate™, 3/8-IN x 16.5 Feet	Jumper	29490629
Manifold Tube Assy ReadyMate™ to ReadyMate™, Tee-Sample, 1/2-IN	Jumper	29453100
3RMY JUMPER 0.5inx6IN TPE1PK	Jumper	12410191

Related literature	Product code
Xcellerex™ APS, Operating instructions (OI)	29365080
Cross flow filtration, Handbook	29085076
ReadyToProcess™ bins, Data file	29108480
ReadyToProcess™ hollow fiber cartridges, Data file	KA349141217DF
Xcellerex™ XDR bioreactor systems, Data file	KA686051217DF

## Common ReadyToProcess™ hollow fiber ultrafilters for perfusion applications\*

Product code	Pore size (µm) or MWCO	Cartridge size	Fiber inner diameter (mm)	Nominal flow path (cm)	Membrane surface area (m <sup>2</sup> )
RTPUFP-10-E-55S	10	55	1	60	2.1
RTPUFP-10-E-65S	10	65	1	60	4.4
RTPUFP-30-E-8S	30	8	1	30	0.36
RTPUFP-30-E-9S	30	9	1	60	0.84
RTPUFP-30-E-55S	30	55	1	60	2.1
RTPUFP-30-E-65S	30	65	1	60	4.4
RTPUFP-50-E-65S	50	65	1	60	4.4
RTPUFP-750-E-5S	750	5	1	30	0.12
RTPUFP-750-E-6S	750	6	1	60	0.28
RTPUFP-750-E-8S	750	8	1	30	0.36
RTPUFP-750-E-9S	750	9	1	60	0.84
RTPUFP-750-E-55S	750	55	1	60	2.1
RTPUFP-750-E-65S	750	65	1	60	4.4

\*Additional options are available.

## Common ReadyToProcess™ hollow fiber microfilters for perfusion applications\*

Product code	Pore size (µm) or MWCO	Cartridge size	Fiber inner diameter (mm)	Nominal flow path (cm)	Membrane surface area (m <sup>2</sup> )
RTPCFP-1-D-6S	0.1	6	0.75	60	0.37
RTPCFP-1-E-5S	0.1	5	1	30	0.12
RTPCFP-1-E-6S	0.1	6	1	60	0.28
RTPCFP-1-E-9S	0.1	9	1	60	0.84
RTPCFP-1-E-45S	0.1	45	1	30	2.5
RTPCFP-1-E-55S	0.1	55	1	60	2.1
RTPCFP-1-E-65S	0.1	65	1	60	4.4
RTPCFP-2-E-5S	0.2	5	1	30	0.12
RTPCFP-2-E-6S	0.2	6	1	60	0.28
RTPCFP-2-E-9S	0.2	9	1	60	0.84
RTPCFP-2-E-45S	0.2	45	1	30	2.5
RTPCFP-2-E-55S	0.2	55	1	60	2.1
RTPCFP-2-E-65S	0.2	65	1	60	4.4
RTPCFP-4-E-5S	0.45	5	1	30	0.12
RTPCFP-4-E-6S	0.45	6	1	60	0.28
RTPCFP-4-E-9S	0.45	9	1	60	0.84
RTPCFP-4-E-45S	0.45	45	1	30	2.5
RTPCFP-4-E-55S	0.45	55	1	60	2.1
RTPCFP-4-E-65S	0.45	65	1	60	4.4

\*Additional options are available.

## cytiva.com

For local office contact information, visit [cytiva.com/contact](https://cytiva.com/contact)

Cytiva and the Drop logo are trademarks of Life Sciences IP Holdings Corporation or an affiliate. ReadyMate, ReadyToProcess, and Xcellerex are trademarks of Global Life Sciences Solutions USA LLC or an affiliate.

The Xcellerex APS (Automated Perfusion System) system is designed for perfusion cell culturing and may therefore be used for a broad variety of cell culture processes (e.g. in the field of intensified and/or continuous cell culturing). Purchaser shall at all times be solely responsible for obtaining any additional intellectual property rights necessary for the use of the Xcellerex APS system for their specific cell culture processes.

ReadyMate: this product is covered by US patent number 6,679,529 B2 owned by Johnson & Boley Holdings, LLC and licensed to Cytiva.

Combics is a trademark of Sartorius Industrial Scales GmbH & Co. Levitronix is a trademark of Levitronix GmbH. Microsoft and Windows are registered trademarks of Microsoft Corporation. PROFIBUS is a trademark of PROFIBUS Nutzerorganisation e.V. Wonderware is a trademark of AVEVA Software. Any other third-party trademarks are the property of their respective owners.

© 2020–2021 Cytiva

CY11407-09Jul21-DF

